

THROUGH FRAME INSTALLATION

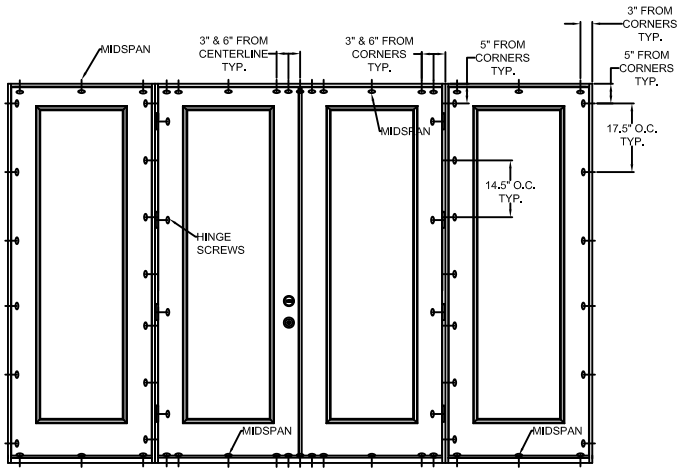

TYPICAL ELEVATION WITH FASTENER SPACING

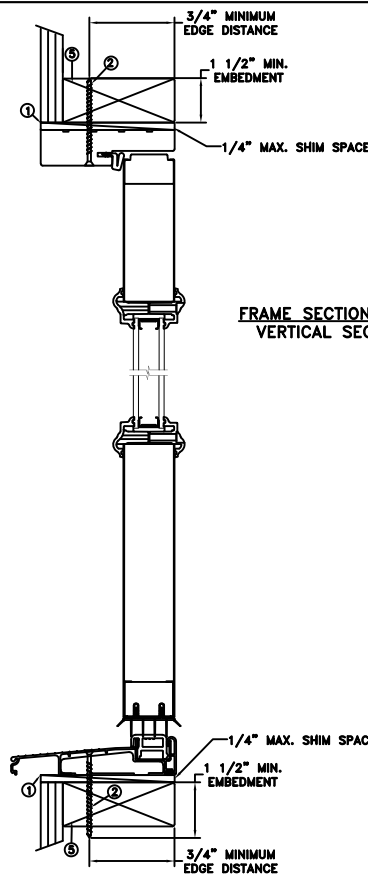

FRAME SECTION (TYP)
VERTICAL SECTION

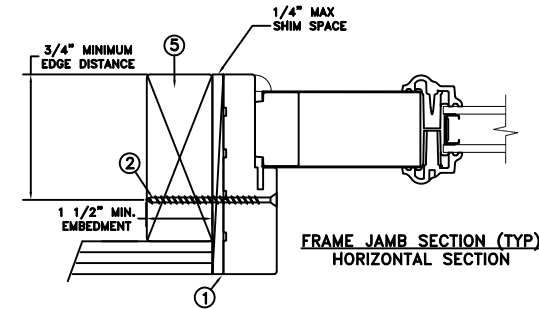

FRAME JAMB SECTION (TYP)
HORIZONTAL SECTION

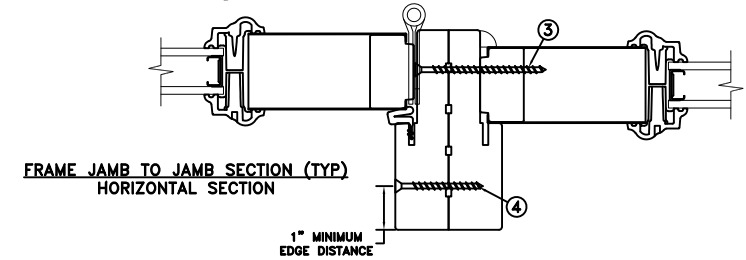

FRAME JAMB TO JAMB SECTION (TYP)
HORIZONTAL SECTION

MAXIMUM FRAME	DP	IMPACT
149 x 98	+35/-35	NO

Installation Notes:

1. Seal flange/frame to substrate. Sill shall be set on a continuous serpentine bead of structural grade silicone caulk when no fastener is used to anchor the sill (typical).
2. Use #10 PH or greater fastener through the head & side jambs with sufficient length to penetrate a minimum of 1 1/2" into the wood framing. For 2x wood frame substrate (min. S.G. = 0.42)
3. Use #9 x 2-1/2" PH screws two (2) per hinge into the jambs.
4. Use #8 x 2" PH fastener at each mullion (min. S.G = 0.42).
5. Host structure (wood buck, masonry, steel) to be designed and anchored to properly transfer all loads to the structure. The host structure is the responsibility of the architect or engineer of record for the project of installation.

General Notes:

1. The product shown herein is designed, tested and manufactured to comply with the wind load criteria of the adopted International Building Code (IBC), the International Residential Code (IRC), the current Florida Building Code (FBC) and the industry requirement for the stated conditions.
2. All glazing shall conform to ASTM E1300.
3. Use structural or composite shims where required.

This item has been digitally signed and sealed by Micah Swartz, P.E. on the date adjacent to the seal.

Printed copies of this document are not considered signed and sealed and the signature must be verified on any electronic copies

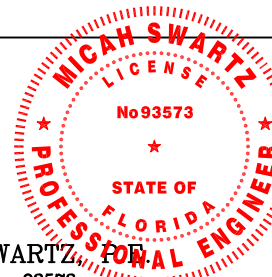

MICAH SWARTZ, P.E.
PE No. 93573
5134 Cambridge Ct.
Klamath Falls, OR. 97603
(541) 363-8075
08/28/24

DATE: 08/26/2024	3737 LAKEPORT BLVD. JELD-WEN KLAMATH FALLS OR, 97601 PHONE: (800) 535-3936
SCALE: NTS	
DRAWN BY: M.HAM	TITLE: Contours Steel Wood Swinging Door Inswing 4 Panel OXXO
CHECKED BY: D.VEZO	
APPROVED BY: D.VEZO	
RECORD No.: D015859	CAD DWG. No.: -
REPORT No.: NCTL-210-3804-3	REV: C
	SHEET 1 of 10

This schedule addresses only the fasteners required to anchor the unit to achieve the rated design pressure and impact performance (where applicable) up to the size limitations noted. It is not intended as a guide to the installation process and does not address the sealing consideration that may arise in different wall conditions. For the complete installation procedure, see the instructions packaged with the unit or go to www.jeld-wen.com.

DISCLAIMER:

This drawing and its contents are confidential and are not to be reproduced or copied in whole or in part or used or disclosed to others except as authorized by JELD-WEN Inc.

MASONRY STRAP INSTALLATION

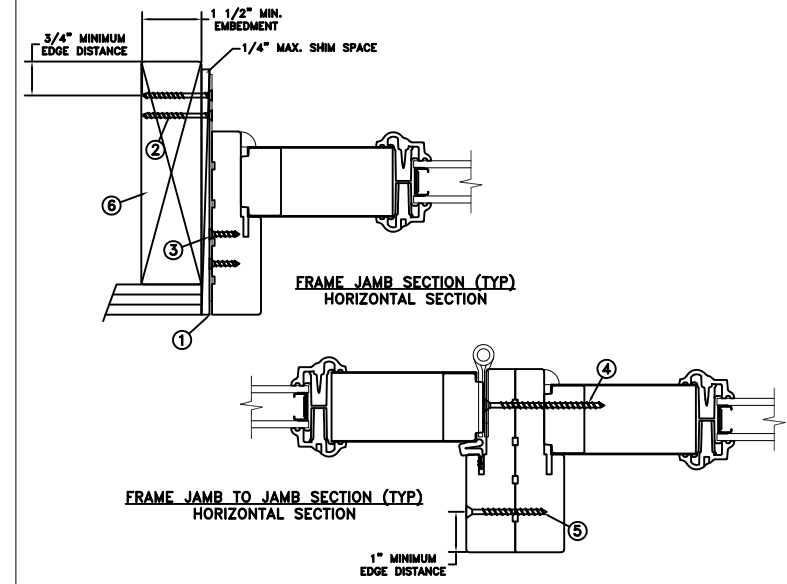
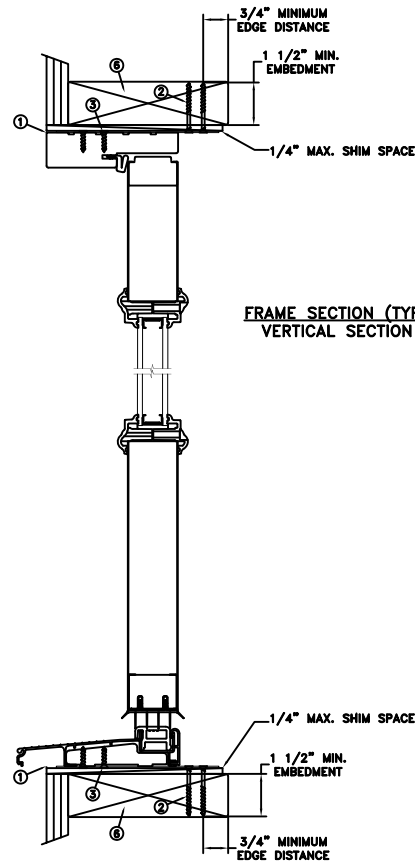
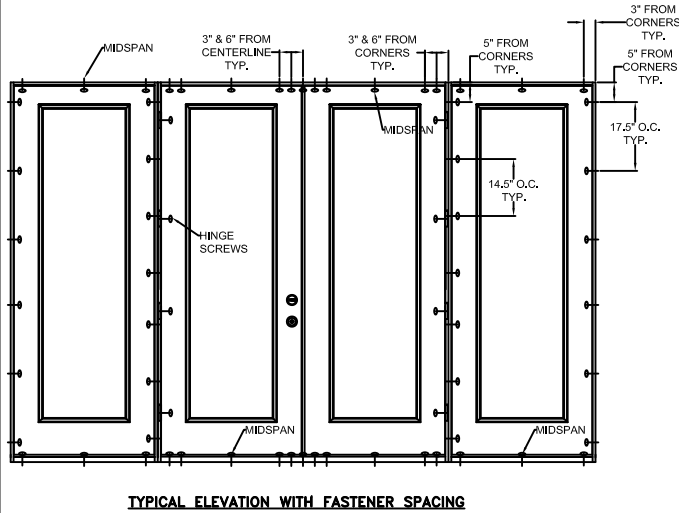

MAXIMUM FRAME	DP	IMPACT
149 x 98	+35/-35	NO

Installation Notes:

1. Seal flange/frame to substrate. Sill shall be set on a continuous serpentine bead of structural grade silicone caulk when no fastener is used to anchor the sill (typical).
2. Use (2) - #8 PFH or larger fasteners through masonry strap with sufficient length to penetrate a minimum of 1 1/2" into the buck. For 2x wood frame substrate (min. S.G. = 0.42).
3. Use (2) - #8 PFH or larger fasteners through masonry strap into jamb without penetrating through the jamb into product causing visibility or collateral damage to product.
4. Use #9 x 2-1/2" PH screw two (2) per hinge into the jambs.
5. Use #8 x 2" PH fastener at each mullion (min. S.G. = 0.42).
6. Host structure (wood buck, masonry, steel) to be designed and anchored to properly transfer all loads to the structure. The host structure is the responsibility of the architect or engineer of record for the project of installation.

General Notes:

1. The product shown herein is designed, tested and manufactured to comply with the wind load criteria of the adopted International Building Code (IBC), the International Residential Code (IRC), the current Florida Building Code (FBC) and the industry requirement for the stated conditions.
2. All glazing shall conform to ASTM E1300.
3. Use structural or composite shims where required.
4. Masonry strap specifications: 20 Ga. galvanized steel, .036" min. thickness x 1.5" min. width.

This item has been digitally signed and sealed by Micah Swartz, P.E. on the date adjacent to the seal.

Printed copies of this document are not considered signed and sealed and the signature must be verified on any electronic copies

This schedule addresses only the fasteners required to anchor the unit to achieve the rated design pressure and impact performance (where applicable) up to the size limitations noted. It is not intended as a guide to the installation process and does not address the sealing consideration that may arise in different wall conditions. For the complete installation procedure, see the instructions packaged with the unit or go to www.jeld-wen.com.

DISCLAIMER:

This drawing and its contents are confidential and are not to be reproduced or copied in whole or in part or used or disclosed to others except as authorized by JELD-WEN Inc.

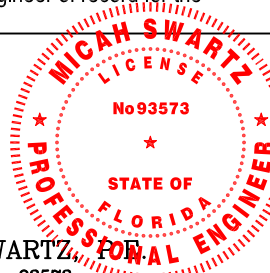

MICAH SWARTZ, P.E.
PE No. 93573
5134 Cambridge Ct.
Klamath Falls, OR. 97603
(541) 363-8075
08/28/24

DATE: 08/26/2024	JELD-WEN 3737 LAKEPORT BLVD. KLAMATH FALLS OR, 97601 PHONE: (800) 535-3936
SCALE: NTS	
DRAWN BY: M.HAM	Contours Steel Wood Swinging Door Inswing 4 Panel OXXO
CHECKED BY: D.Vezo	
APPROVED BY: D.Vezo	
RECORD No.:	
D015859	
REPORT No.:	
NCTL-210-3804-3	
CAD DWG. No.:	REV: C SHEET 2 of 10
—	

CONCRETE/MASONRY
INSTALLATION

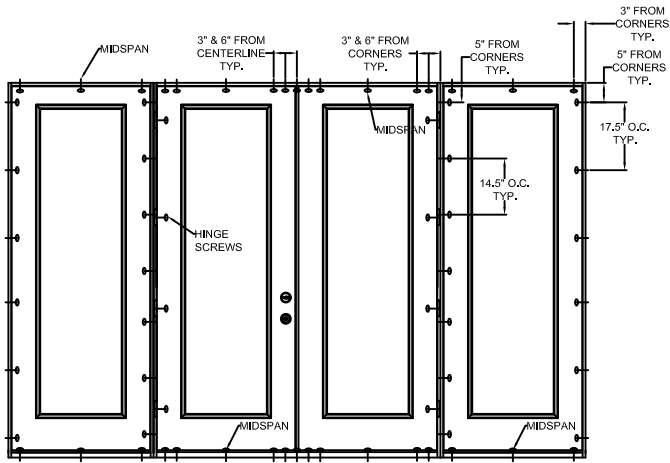

TYPICAL ELEVATION WITH FASTENER SPACING

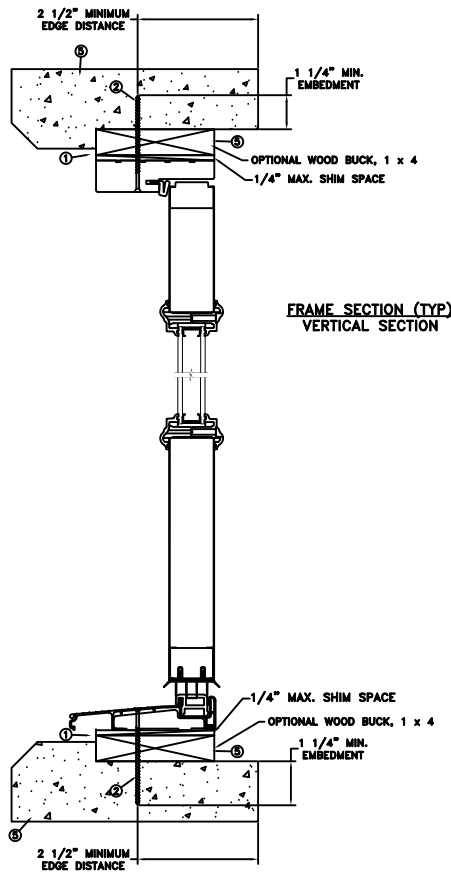

FRAME SECTION (TYP)
VERTICAL SECTION

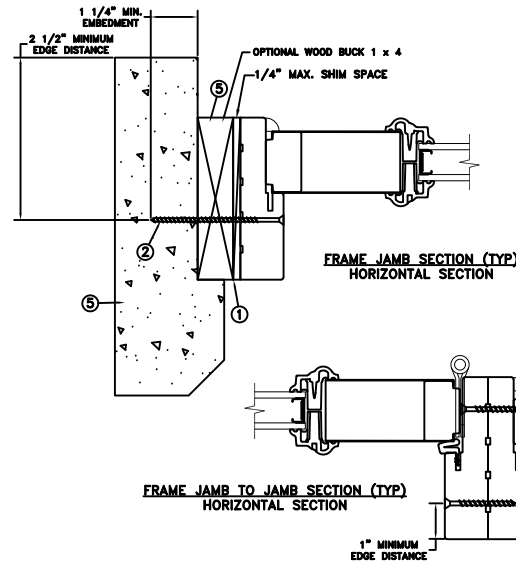

FRAME JAMB SECTION (TYP)
HORIZONTAL SECTION

FRAME JAMB TO JAMB SECTION (TYP)
HORIZONTAL SECTION

MAXIMUM FRAME	DP	IMPACT
149 x 98	+35/-35	NO

Installation Notes:

1. Seal flange/frame to substrate. Sill shall be set on a continuous serpentine bead of structural grade silicone caulk when no fastener is used to anchor the sill (typical).
2. Use 1/4" tapcon or equivalent fasteners through frame with sufficient length to penetrate a minimum of 1 1/4" into concrete or masonry at each location with a 2 1/2" min. from edge distance. For concrete (min. fc = 3000 psi) or masonry substrate (CMU shall adhere to ASTM C90).
3. Use #9 x 2-1/2" PH screw two (2) per hinge into the jambs.
4. Use #8 x 2" PH fastener at each mullion (min. S.G. = 0.42).
5. Host structure (wood buck, masonry, steel) to be designed and anchored to properly transfer all loads to the structure. The host structure is the responsibility of the architect or engineer of record for the project of installation.

General Notes:

1. The product shown herein is designed, tested and manufactured to comply with the wind load criteria of the adopted International Building Code (IBC), the International Residential Code (IRC), the current Florida Building Code (FBC) and the industry requirement for the stated conditions.
2. All glazing shall conform to ASTM E1300.
3. Use structural or composite shims where required.

This item has been digitally signed and sealed by Micah Swartz, P.E. on the date adjacent to the seal.

Printed copies of this document are not considered signed and sealed and the signature must be verified on any electronic copies

This schedule addresses only the fasteners required to anchor the unit to achieve the rated design pressure and impact performance (where applicable) up to the size limitations noted. It is not intended as a guide to the installation process and does not address the sealing consideration that may arise in different wall conditions. For the complete installation procedure, see the instructions packaged with the unit or go to www.jeld-wen.com.

DISCLAIMER:

This drawing and its contents are confidential and are not to be reproduced or copied in whole or in part or used or disclosed to others except as authorized by JELD-WEN Inc.

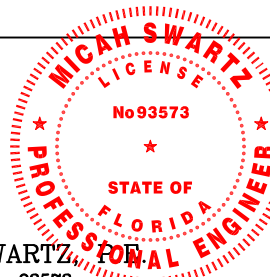

MICAH SWARTZ, P.E.
PE No. 93573
5134 Cambridge Ct.
Klamath Falls, OR. 97603
(541) 363-8075
08/28/24

DATE: 08/26/2024	3737 LAKEPORT BLVD. JELD-WEN KLAMATH FALLS OR, 97601 PHONE: (800) 535-3936
SCALE: NTS	
DRAWN BY: M.HAM	Contours Steel Wood Swinging Door Inswing 4 Panel OXXO
CHECKED BY: D.VEZO	
APPROVED BY: D.VEZO	
RECORD No.:	
D015859	
REPORT No.:	
NCTL-210-3804-3	
CAD DWG. No.:	REV: C SHEET 3 of 10
-	

CONCRETE/MASONRY
INSTALLATION

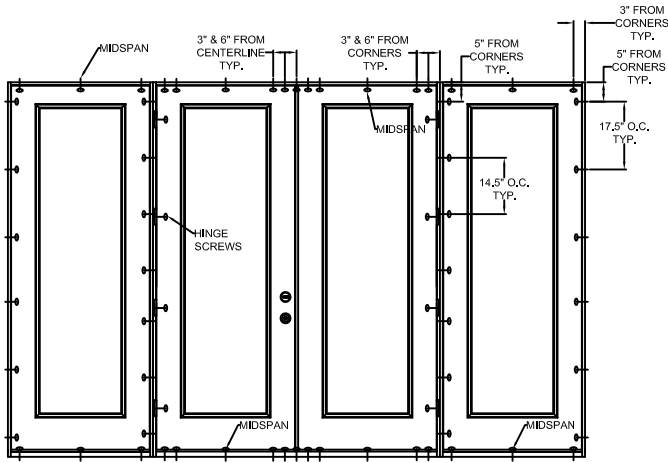

TYPICAL ELEVATION WITH FASTENER SPACING

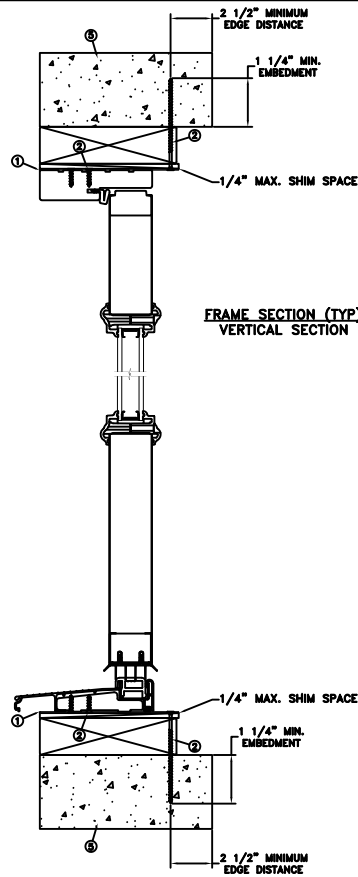

FRAME SECTION (TYP)
VERTICAL SECTION

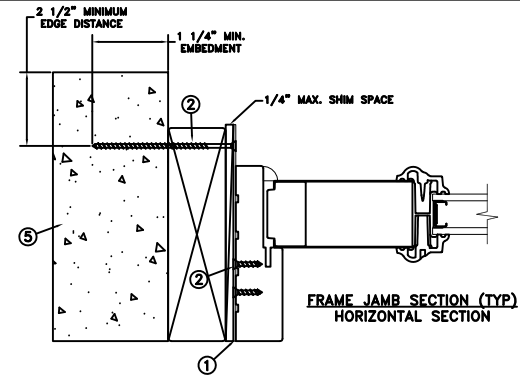

FRAME JAMB SECTION (TYP)
HORIZONTAL SECTION

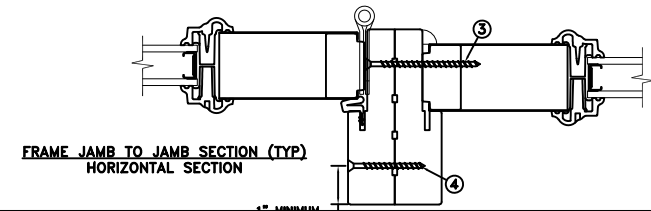

FRAME JAMB TO JAMB SECTION (TYP)
HORIZONTAL SECTION

MAXIMUM FRAME	DP	IMPACT
149 x 98	+35/-35	NO

Installation Notes:

1. Seal flange/frame to substrate. Sill shall be set on a continuous serpentine bead of structural grade silicone caulk when no fastener is used to anchor the sill (typical).
2. Use (1) - 1/4" Tapcon or equivalent fasteners through strap with sufficient length to penetrate a minimum of 1 1/4" into concrete or masonry at each location with a 2 1/2" min. from edge distance. Use (2) - #8 PFH fasteners through masonry strap into frame. For concrete (min. fc = 3000 psi) or masonry substrate (CMU shall adhere to ASTM C90).
3. Use #9 x 2-1/2" PH screw two (2) per hinge into the jambs.
4. Use #8 x 2" PH fastener at each mullion (min. S.G. = 0.42).
5. Host structure (wood buck, masonry, steel) to be designed and anchored to properly transfer all loads to the structure. The host structure is the responsibility of the architect or engineer of record for the project of installation.

General Notes:

1. The product shown herein is designed, tested and manufactured to comply with the wind load criteria of the adopted International Building Code (IBC), the International Residential Code (IRC), the current Florida Building Code (FBC) and the industry requirement for the stated conditions.
2. All glazing shall conform to ASTM E1300.
3. Use structural or composite shims where required.
4. Masonry strap specifications: 20 Ga. galvanized steel, .036" min. thickness x 1.5" min. width.

This item has been digitally signed and sealed by Micah Swartz, P.E. on the date adjacent to the seal.

Printed copies of this document are not considered signed and sealed and the signature must be verified on any electronic copies

This schedule addresses only the fasteners required to anchor the unit to achieve the rated design pressure and impact performance (where applicable) up to the size limitations noted. It is not intended as a guide to the installation process and does not address the sealing consideration that may arise in different wall conditions. For the complete installation procedure, see the instructions packaged with the unit or go to www.jeld-wen.com.

DISCLAIMER:

This drawing and its contents are confidential and are not to be reproduced or copied in whole or in part or used or disclosed to others except as authorized by JELD-WEN Inc.

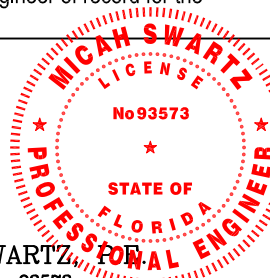

MICAH SWARTZ, P.E.
PE No. 93573
5134 Cambridge Ct.
Klamath Falls, OR. 97603
(541) 363-8075
08/28/24

DATE: 08/26/2024	3737 LAKEPORT BLVD. JELD-WEN KLAMATH FALLS OR, 97601 PHONE: (800) 535-3936		
SCALE: NTS			
CHECKED BY: D. VEZO	TITLE: Contours Steel Wood Swinging Door Inswing 4 Panel OXXO		
APPROVED BY: D. VEZO			
RECORD No.: D015859			
REPORT No.: NCTL-210-3804-3	CAD DWG. No.: -	REV: C	SHEET 4 of 10

MASONRY STRAP INSTALLATION

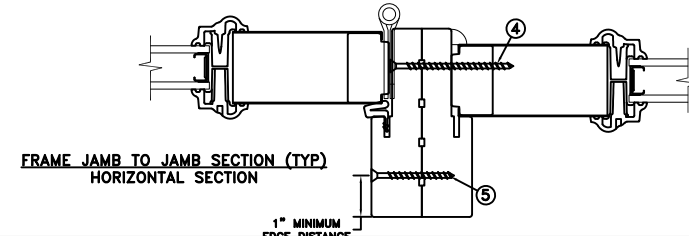
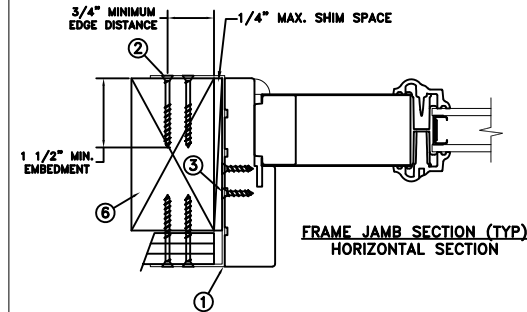
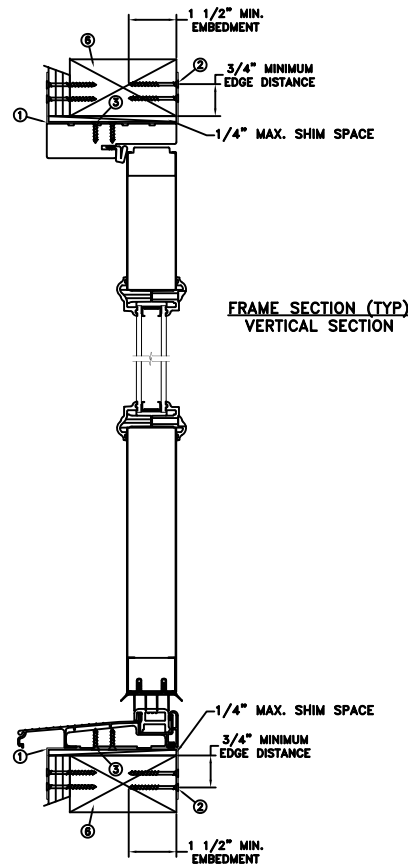
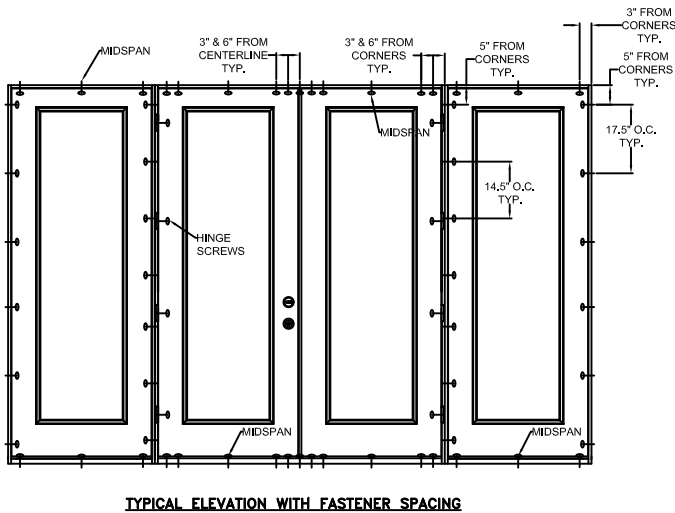

MAXIMUM FRAME	DP	IMPACT
149 x 98	+35/-35	NO

Installation Notes:

1. Seal flange/frame to substrate. Sill shall be set on a continuous serpentine bead of structural grade silicone caulk when no fastener is used to anchor the sill (typical).
2. Use min. (2) - #8 PFH or larger fasteners through masonry strap with sufficient length to penetrate a minimum of 1 1/2" into the buck. Bend straps around both sides of the buck. For 2x wood frame substrate (min. S.G. = 0.42).
3. Use min. (2) - #8 PFH or larger fasteners through masonry strap into jamb without penetrating through the jamb into product causing visibility or collateral damage to product.
4. Use #9 x 2-1/2" PH screw two (2) per hinge into the jambs.
5. Use #8 x 2" PH fastener at each mullion (min. S.G. = 0.42).
6. Host structure (wood buck, masonry, steel) to be designed and anchored to properly transfer all loads to the structure. The host structure is the responsibility of the architect or engineer of record for the project of installation.

General Notes:

1. The product shown herein is designed, tested and manufactured to comply with the wind load criteria of the adopted International Building Code (IBC), the International Residential Code (IRC), the current Florida Building Code (FBC) and the industry requirement for the stated conditions.
2. All glazing shall conform to ASTM E1300.
3. Use structural or composite shims where required.
4. Masonry strap specifications: 20 Ga. galvanized steel, .036" min. thickness x 1.5" min. width.

This item has been digitally signed and sealed by Micah Swartz, P.E. on the date adjacent to the seal.

Printed copies of this document are not considered signed and sealed and the signature must be verified on any electronic copies

This schedule addresses only the fasteners required to anchor the unit to achieve the rated design pressure and impact performance (where applicable) up to the size limitations noted. It is not intended as a guide to the installation process and does not address the sealing consideration that may arise in different wall conditions. For the complete installation procedure, see the instructions packaged with the unit or go to www.jeld-wen.com.

DISCLAIMER:

This drawing and its contents are confidential and are not to be reproduced or copied in whole or in part or used or disclosed to others except as authorized by JELD-WEN Inc.

MICAH SWARTZ
PE No. 93573
5134 Cambridge Ct.
Klamath Falls, OR. 97603
(541) 363-8075

08/28/24

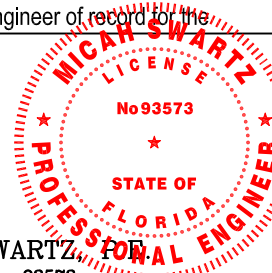

DATE: 08/26/2024	3737 LAKEPORT BLVD. KLAMATH FALLS OR, 97601 PHONE: (800) 535-3936
DRAWN BY: M.HAM	<p>JELD-WEN</p> <p>Contours Steel Wood Swinging Door Inswing 4 Panel OXXO</p>
CHECKED BY: D.VEZO	
APPROVED BY: D.VEZO	
RECORD No.: D015859	
REPORT No.: NCTL-210-3804-3	CAD DWG. No.: -
	REV: C SHEET 5 of 10

THROUGH FRAME
INSTALLATION

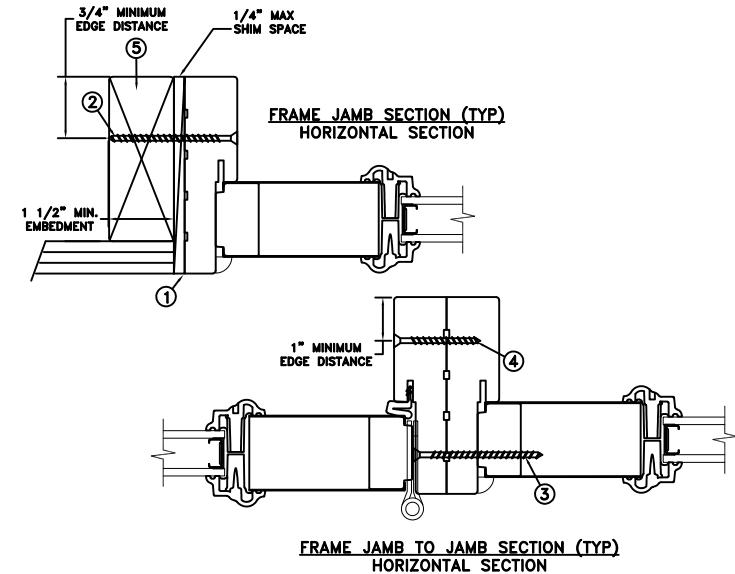
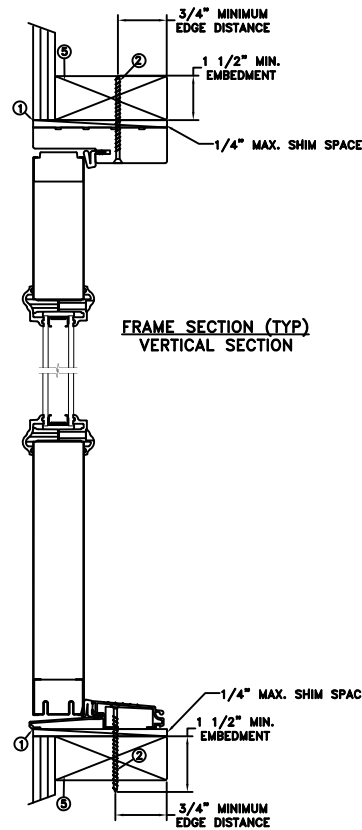
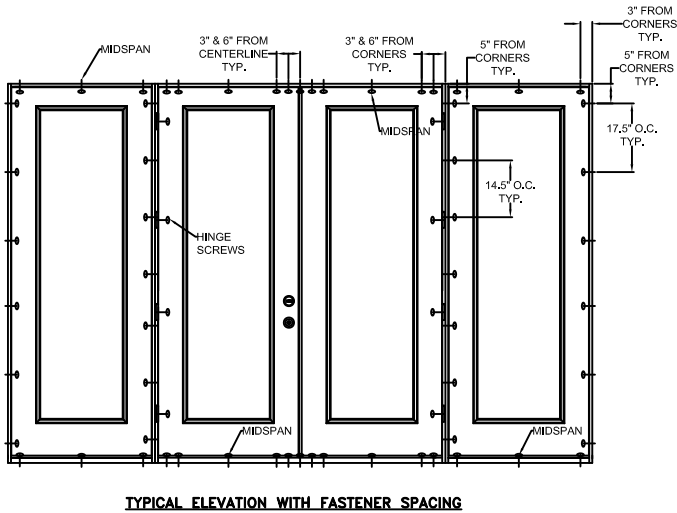

MAXIMUM FRAME	DP	IMPACT
149 x 97	+35/-35	NO

Installation Notes:

1. Seal flange/frame to substrate. Sill shall be set on a continuous serpentine bead of structural grade silicone caulk when no fastener is used to anchor the sill (typical).
2. Use #10 PH or greater fastener through the head & side jambs with sufficient length to penetrate a minimum of 1 1/2" into the wood framing. For 2x wood frame substrate (min. S.G. = 0.42)
3. Use #9 x 2-1/2" PH screws two (2) per hinge into the jambs.
4. Use #8 x 2" PH fastener at each mullion (min. S.G = 0.42).
5. Host structure (wood buck, masonry, steel) to be designed and anchored to properly transfer all loads to the structure. The host structure is the responsibility of the architect or engineer of record for the project of installation.

General Notes:

1. The product shown herein is designed, tested and manufactured to comply with the wind load criteria of the adopted International Building Code (IBC), the International Residential Code (IRC), the current Florida Building Code (FBC) and the industry requirement for the stated conditions.
2. All glazing shall conform to ASTM E1300.
3. Use structural or composite shims where required.

This item has been digitally signed and sealed by Micah Swartz, P.E. on the date adjacent to the seal.

Printed copies of this document are not considered signed and sealed and the signature must be verified on any electronic copies

This schedule addresses only the fasteners required to anchor the unit to achieve the rated design pressure and impact performance (where applicable) up to the size limitations noted. It is not intended as a guide to the installation process and does not address the sealing consideration that may arise in different wall conditions. For the complete installation procedure, see the instructions packaged with the unit or go to www.jeld-wen.com.

DISCLAIMER:

This drawing and its contents are confidential and are not to be reproduced or copied in whole or in part or used or disclosed to others except as authorized by JELD-WEN Inc.

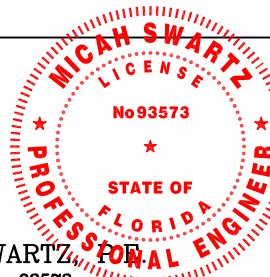

MICAH SWARTZ, P.E.
PE No. 93573
5134 Cambridge Ct.
Klamath Falls, OR. 97603
(541) 363-8075
08/28/24

DATE: 08/26/2024	3737 LAKEPORT BLVD. JELD-WEN KLAMATH FALLS OR, 97601 PHONE: (800) 535-3936
SCALE: NTS	
DRAWN BY: M.HAM	TITLE: Contours Steel Wood Swinging Door Outswing 4 Panel OXXO
CHECKED BY: D.Vezo	
APPROVED BY: D.Vezo	
RECORD No.: D015859	CAD DWG. No.: -
REPORT No.: NCTL-210-3804-4	REV: C
	SHEET 6 of 10

MASONRY STRAP INSTALLATION

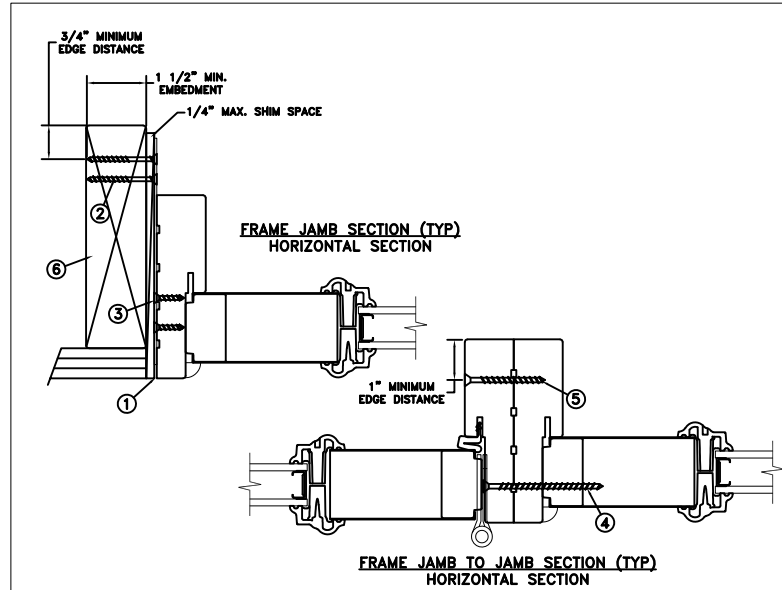
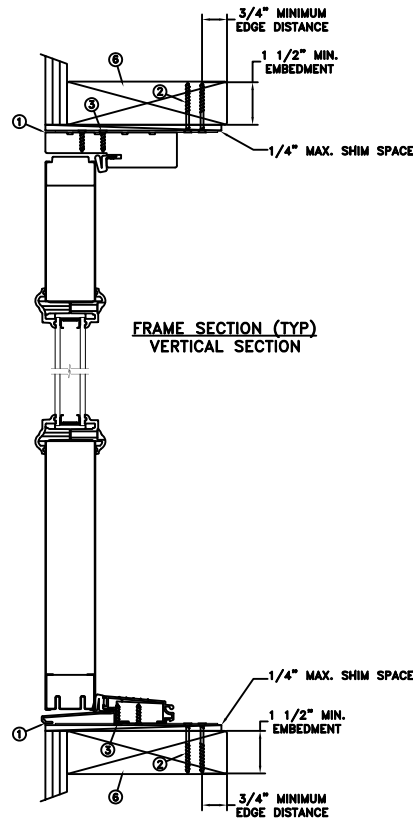
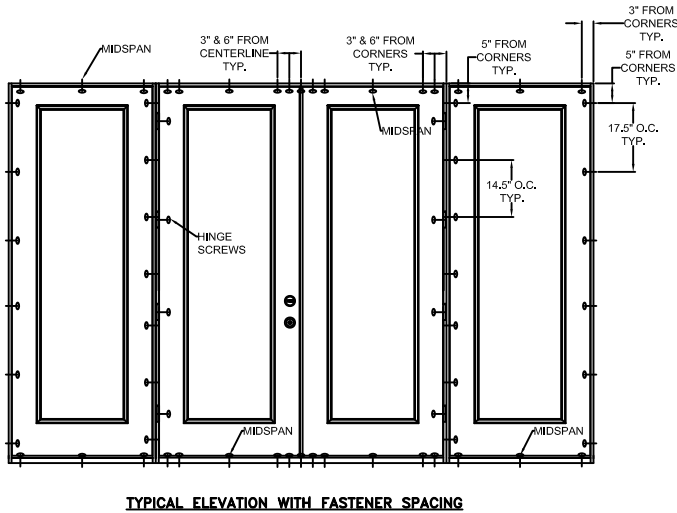

MAXIMUM FRAME	DP	IMPACT
149 x 97	+35/-35	NO

Installation Notes:

1. Seal flange/frame to substrate. Sill shall be set on a continuous serpentine bead of structural grade silicone caulk when no fastener is used to anchor the sill (typical).
2. Use (2) - #8 PFH or larger fasteners through masonry strap with sufficient length to penetrate a minimum of 1 1/2" into the buck. For 2x wood frame substrate (min. S.G. = 0.42).
3. Use (2) - #8 PFH or larger fasteners through masonry strap into jamb without penetrating through the jamb into product causing visibility or collateral damage to product.
4. Use #9 x 2-1/2" PH screw two (2) per hinge into the jambs.
5. Use #8 x 2" PH fastener at each mullion (min. S.G. = 0.42).
6. Host structure (wood buck, masonry, steel) to be designed and anchored to properly transfer all loads to the structure. The host structure is the responsibility of the architect or engineer of record for the project of installation.

General Notes:

1. The product shown herein is designed, tested and manufactured to comply with the wind load criteria of the adopted International Building Code (IBC), the International Residential Code (IRC), the current Florida Building Code (FBC) and the industry requirement for the stated conditions.
2. All glazing shall conform to ASTM E1300.
3. Use structural or composite shims where required.
4. Masonry strap specifications: 20 Ga. galvanized steel, .036" min. thickness x 1.5" min. width.

This item has been digitally signed and sealed by Micah Swartz, P.E. on the date adjacent to the seal.

Printed copies of this document are not considered signed and sealed and the signature must be verified on any electronic copies

This schedule addresses only the fasteners required to anchor the unit to achieve the rated design pressure and impact performance (where applicable) up to the size limitations noted. It is not intended as a guide to the installation process and does not address the sealing consideration that may arise in different wall conditions. For the complete installation procedure, see the instructions packaged with the unit or go to www.jeld-wen.com.

DISCLAIMER:

This drawing and its contents are confidential and are not to be reproduced or copied in whole or in part or used or disclosed to others except as authorized by JELD-WEN Inc.

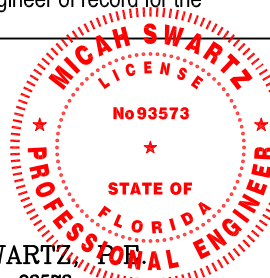

MICAH SWARTZ, P.E.
PE No. 93573
5134 Cambridge Ct.
Klamath Falls, OR. 97603
(541) 363-8075
08/28/24

DATE: 08/26/2024	3737 LAKEPORT BLVD. KLAMATH FALLS OR, 97601 PHONE: (800) 535-3936
DRAWN BY: M.HAM	JELD-WEN Contours Steel Wood Swinging Door Outswing 4 Panel OXXO
CHECKED BY: D.Vezo	
APPROVED BY: D.Vezo	TITLE:
RECORD No.: D015859	CAD DWG. No.: -
REPORT No.: NCTL-210-3804-4	REV: C
	SHEET 7 of 10

CONCRETE/MASONRY
INSTALLATION

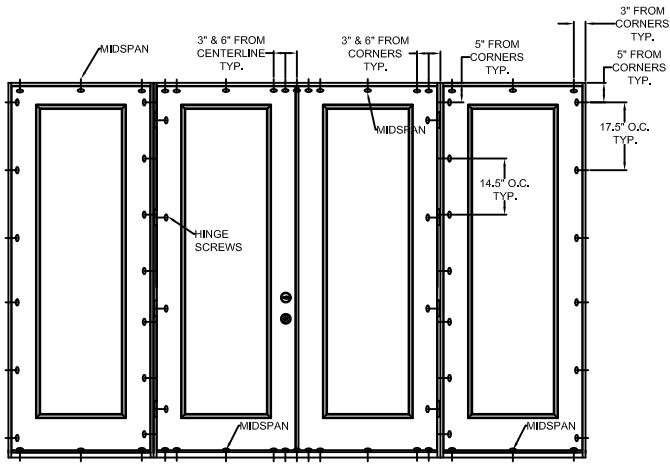

TYPICAL ELEVATION WITH FASTENER SPACING

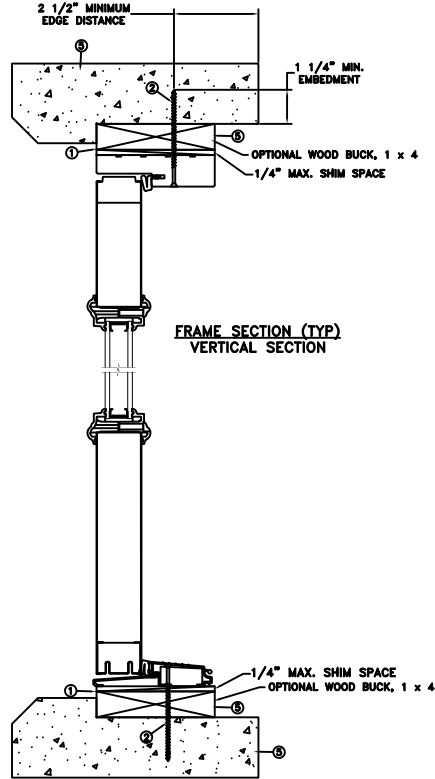

FRAME SECTION (TYP)
VERTICAL SECTION

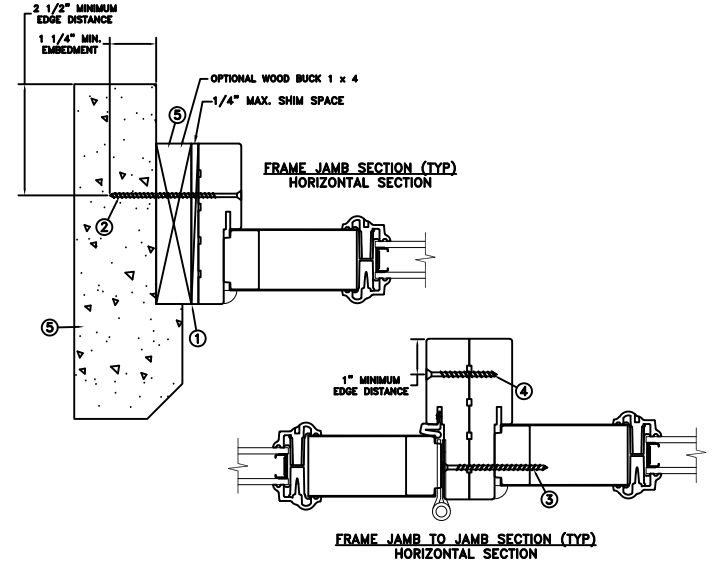

FRAME JAMB SECTION (TYP)
HORIZONTAL SECTION

FRAME JAMB TO JAMB SECTION (TYP)
HORIZONTAL SECTION

MAXIMUM FRAME	DP	IMPACT
149 x 97	+35/-35	NO

Installation Notes:

1. Seal flange/frame to substrate. Sill shall be set on a continuous serpentine bead of structural grade silicone caulk when no fastener is used to anchor the sill (typical).
2. Use 1/4" tapcon or equivalent fasteners through frame with sufficient length to penetrate a minimum of 1 1/4" into concrete or masonry at each location with a 2 1/2" min. from edge distance. For concrete (min. fc = 3000 psi) or masonry substrate (CMU shall adhere to ASTM C90).
3. Use #9 x 2-1/2" PH screw two (2) per hinge into the jambs.
4. Use #8 x 2" PH fastener at each mullion (min. S.G. = 0.42).
5. Host structure (wood buck, masonry, steel) to be designed and anchored to properly transfer all loads to the structure. The host structure is the responsibility of the architect or engineer of record for the project of installation.

General Notes:

1. The product shown herein is designed, tested and manufactured to comply with the wind load criteria of the adopted International Building Code (IBC), the International Residential Code (IRC), the current Florida Building Code (FBC) and the industry requirement for the stated conditions.
2. All glazing shall conform to ASTM E1300.
3. Use structural or composite shims where required.

This item has been digitally signed and sealed by Micah Swartz, P.E. on the date adjacent to the seal.

Printed copies of this document are not considered signed and sealed and the signature must be verified on any electronic copies

This schedule addresses only the fasteners required to anchor the unit to achieve the rated design pressure and impact performance (where applicable) up to the size limitations noted. It is not intended as a guide to the installation process and does not address the sealing consideration that may arise in different wall conditions. For the complete installation procedure, see the instructions packaged with the unit or go to www.jeld-wen.com.

DISCLAIMER:

This drawing and its contents are confidential and are not to be reproduced or copied in whole or in part or used or disclosed to others except as authorized by JELD-WEN Inc.

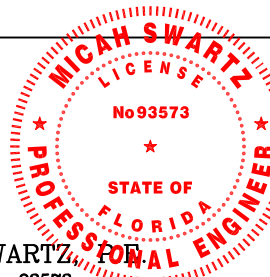

MICAH SWARTZ, P.E.
PE No. 93573
5134 Cambridge Ct.
Klamath Falls, OR. 97603
(541) 363-8075
08/28/24

DATE: 08/26/2024	3737 LAKEPORT BLVD. JELD-WEN KLAMATH FALLS OR, 97601 PHONE: (800) 535-3936		
SCALE: NTS			
CHECKED BY: D. VEZO	TITLE: Contours Steel Wood Swinging Door Outswing 4 Panel OXXO		
APPROVED BY: D. VEZO			
RECORD No.: D015859			
REPORT No.: NCTL-210-3804-4	CAD DWG. No.: -	REV: C	SHEET 8 of 10

CONCRETE/MASONRY
INSTALLATION

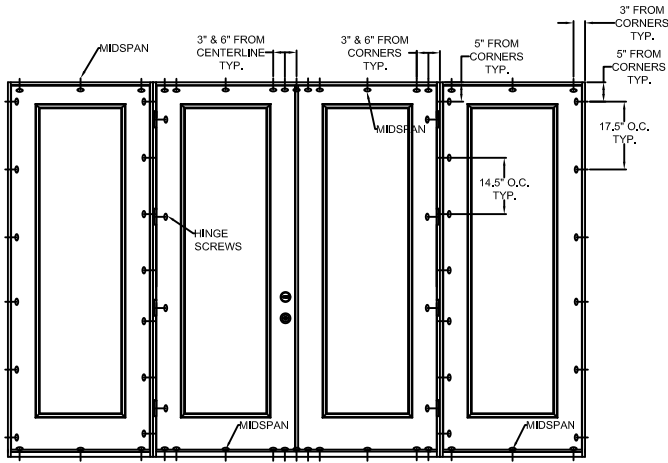

TYPICAL ELEVATION WITH FASTENER SPACING

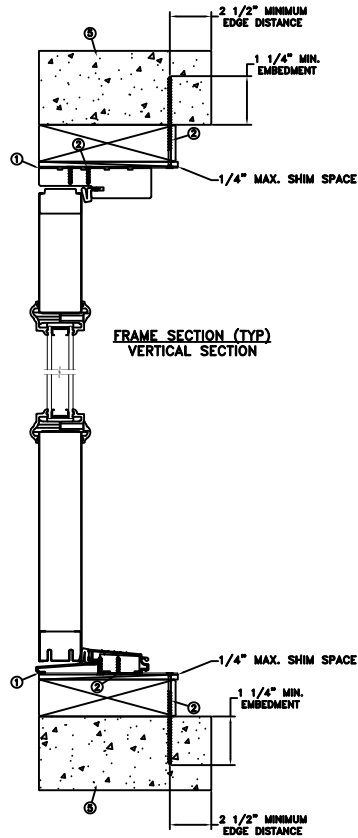

FRAME SECTION (TYP)
VERTICAL SECTION

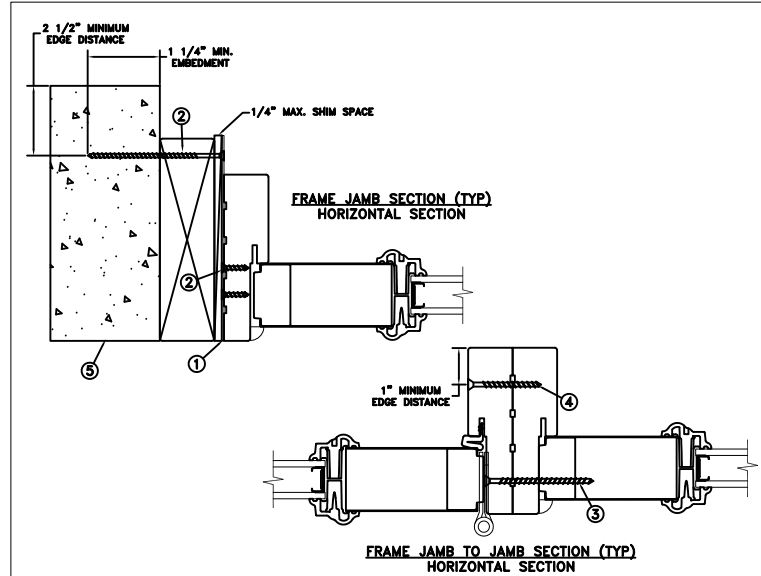

FRAME JAMB SECTION (TYP)
HORIZONTAL SECTION

1" MINIMUM
EDGE DISTANCE

FRAME JAMB TO JAMB SECTION (TYP)
HORIZONTAL SECTION

MAXIMUM FRAME	DP	IMPACT
149 x 97	+35/-35	NO

Installation Notes:

1. Seal flange/frame to substrate. Sill shall be set on a continuous serpentine bead of structural grade silicone caulk when no fastener is used to anchor the sill (typical).
2. Use (1) - 1/4" Tapcon or equivalent fasteners through strap with sufficient length to penetrate a minimum of 1 1/4" into concrete or masonry at each location with a 2 1/2" min. from edge distance. Use (2) - #8 PFH fasteners through masonry strap into frame. For concrete (min. fc = 3000 psi) or masonry substrate (CMU shall adhere to ASTM C90).
3. Use #9 x 2-1/2" PH screw two (2) per hinge into the jambs.
4. Use #8 x 2" PH fastener at each mullion (min. S.G. = 0.42).
5. Host structure (wood buck, masonry, steel) to be designed and anchored to properly transfer all loads to the structure. The host structure is the responsibility of the architect or engineer of record for the project of installation.

General Notes:

1. The product shown herein is designed, tested and manufactured to comply with the wind load criteria of the adopted International Building Code (IBC), the International Residential Code (IRC), the current Florida Building Code (FBC) and the industry requirement for the stated conditions.
2. All glazing shall conform to ASTM E1300.
3. Use structural or composite shims where required.
4. Masonry strap specifications: 20 Ga. galvanized steel, .036" min. thickness x 1.5" min. width.

This item has been digitally signed and sealed by Micah Swartz, P.E. on the date adjacent to the seal.

Printed copies of this document are not considered signed and sealed and the signature must be verified on any electronic copies

This schedule addresses only the fasteners required to anchor the unit to achieve the rated design pressure and impact performance (where applicable) up to the size limitations noted. It is not intended as a guide to the installation process and does not address the sealing consideration that may arise in different wall conditions. For the complete installation procedure, see the instructions packaged with the unit or go to www.jeld-wen.com.

DISCLAIMER:
This drawing and its contents are confidential and are not to be reproduced or copied in whole or in part or used or disclosed to others except as authorized by JELD-WEN Inc.

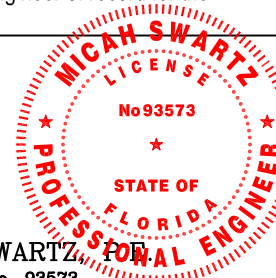

MICAH SWARTZ, P.E.
PE No. 93573
5134 Cambridge Ct.
Klamath Falls, OR. 97603
(541) 363-8075
08/28/24

DATE: 08/26/2024	3737 LAKEPORT BLVD. JELD-WEN KLAMATH FALLS OR, 97601 PHONE: (800) 535-3936		
SCALE: NTS			
DRAWN BY: M.HAM	TITLE: Contours Steel Wood Swinging Door Outswing 4 Panel OXXO		
CHECKED BY: D.VEZO			
APPROVED BY: D.VEZO			
RECORD No.: D015859			
REPORT No.: NCTL-210-3804-4	CAD DWG. No.: -	REV: C	SHEET 9 of 10

MASONRY STRAP INSTALLATION

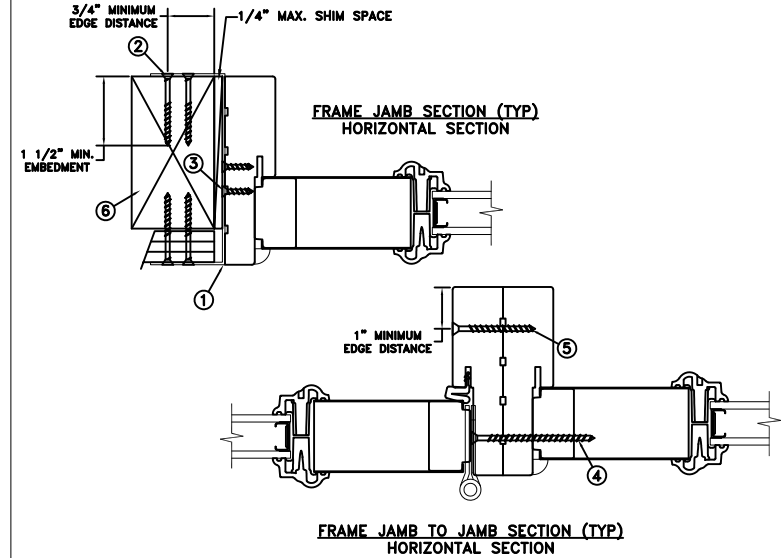
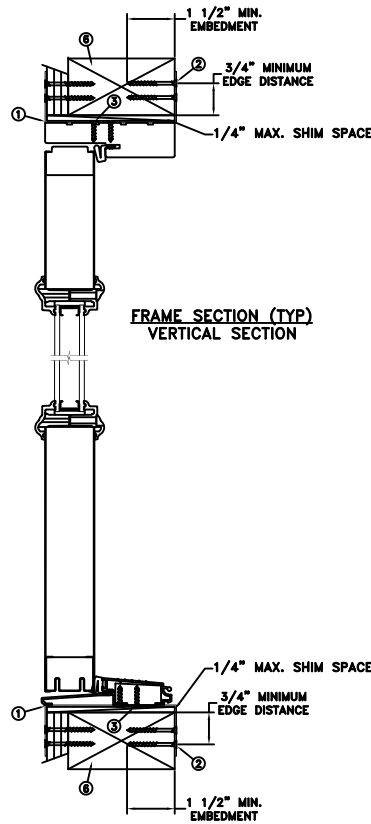
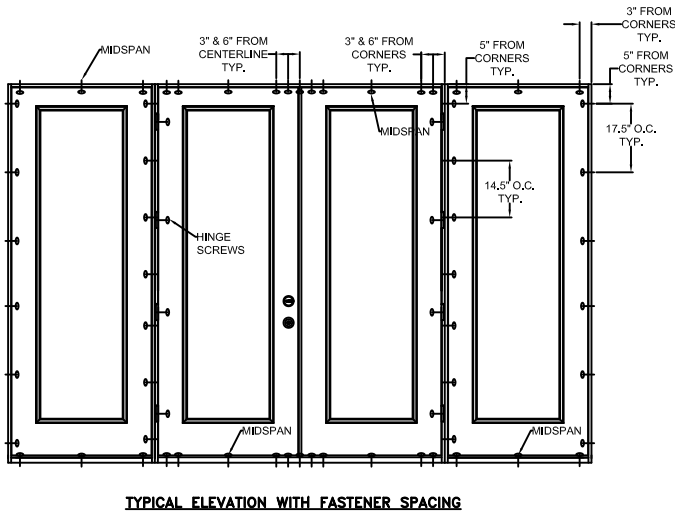

MAXIMUM FRAME	DP	IMPACT
149 x 97	+35/-35	NO

Installation Notes:

1. Seal flange/frame to substrate. Sill shall be set on a continuous serpentine bead of structural grade silicone caulk when no fastener is used to anchor the sill (typical).
2. Use min. (2) - #8 PFH or larger fasteners through masonry strap with sufficient length to penetrate a minimum of 1 1/2" into the buck. Bend straps around both sides of the buck. For 2x wood frame substrate (min. S.G. = 0.42).
3. Use min. (2) - #8 PFH or larger fasteners through masonry strap into jamb without penetrating through the jamb into product causing visibility or collateral damage to product.
4. Use #9 x 2-1/2" PH screw two (2) per hinge into the jambs.
5. Use #8 x 2" PH fastener at each mullion (min. S.G. = 0.42).
6. Host structure (wood buck, masonry, steel) to be designed and anchored to properly transfer all loads to the structure. The host structure is the responsibility of the architect or engineer of record for the project of installation.

General Notes:

1. The product shown herein is designed, tested and manufactured to comply with the wind load criteria of the adopted International Building Code (IBC), the International Residential Code (IRC), the current Florida Building Code (FBC) and the industry requirement for the stated conditions.
2. All glazing shall conform to ASTM E1300.
3. Use structural or composite shims where required.
4. Masonry strap specifications: 20 Ga. galvanized steel, .036" min. thickness x 1.5" min. width.

This item has been digitally signed and sealed by Micah Swartz, P.E. on the date adjacent to the seal.

Printed copies of this document are not considered signed and sealed and the signature must be verified on any electronic copies

This schedule addresses only the fasteners required to anchor the unit to achieve the rated design pressure and impact performance (where applicable) up to the size limitations noted. It is not intended as a guide to the installation process and does not address the sealing consideration that may arise in different wall conditions. For the complete installation procedure, see the instructions packaged with the unit or go to www.jeld-wen.com.

DISCLAIMER:

This drawing and its contents are confidential and are not to be reproduced or copied in whole or in part or used or disclosed to others except as authorized by JELD-WEN Inc.

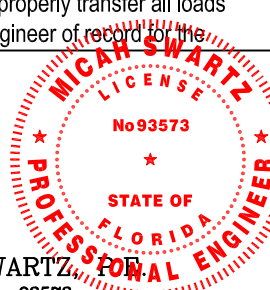

MICAH SWARTZ, P.E.
PE No. 93573
5134 Cambridge Ct.
Klamath Falls, OR. 97603
(541) 363-8075
08/28/24

DATE: 08/26/2024	3737 LAKEPORT BLVD. KLAMATH FALLS OR, 97601 PHONE: (800) 535-3936
DRAWN BY: M.HAM	<h1>JELD-WEN</h1> <p>Contours Steel Wood Swinging Door Outswing 4 Panel OXXO</p>
CHECKED BY: D.Vezo	
APPROVED BY: D.Vezo	
RECORD No.: D015859	
REPORT No.: NCTL-210-3804-4	CAD DWG. No.: -
	REV: C SHEET 10 of 10